



ACME ENGINEERING &
MANUFACTURING CORP.
P.O. Box 978
Muskogee, Oklahoma 74402
AcmeFan.com

Form 610427

INSTALLATION & MAINTENANCE INSTRUCTIONS BREEZEMASTER MODEL BDR/ADR W/WSS & WSSC

This set of instructions applies to both the direct driven and belt driven fans with WSS slant housing and the WSSC slant collar. **CAUTION:** Model ADR36G8 should not be operated with a timer.

WARNING! Do not use fans in hazardous environments where the fan's electrical system could provide ignition to combustible or flammable materials, unless built specifically for that environment. This unit has rotating parts and safety precautions should be exercised during installation, operation and maintenance.

Remove from shipping crate prior to installation. All debris and shipping material must be removed to prevent obstruction of air flow to and from the orifice. The orifice opening on both sides must be kept clear of obstructions. Failure to keep the orifice opening clear could cause undue stresses on the propeller blades, damage to the fan, and an unsafe operating condition.

Minimum Fan Center to Center Spacing Cone Fans

SIZE	N	
	IN	mm
BDR/ADR36	45.13	1146
BDR48	59.45	1510
BDR48J2	62.38	1584
BDR54	67.00	1702

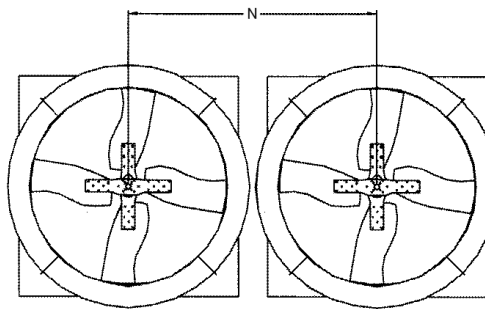

Note: This minimum distance will place the fans in a side by side position with the cones touching.

BDR COMPONENTS		
CODE	DESCRIPTION	QTY.
1	Roll Pin	1
2	Propeller	1
3	5/16 Whiz Lock Nut	20
4	Orifice	1
5	Support Angle	2
6	5/16 X 3/4 Bolt	24
7	Bearing Base	2
8	Bearing	2
9	Shaft	1
10	Fan Sheave (with or without housing)	1
11	Motor Base	1
12	Rubber Ring	2
13	Motor	1
14	Motor Sheave	1
15	Belt	1
16	Belt Tightener	1
17	Belt Tightener Bracket	1
18	1/4 x 3/4 Bolt	2
19	1/4 Whiz Lock Nut	2
20	Key 8mm x 8mm	1
21	3/8 Lock Washer	1
22	3/8 x 1 1/4 bolt	1
23	Cable Clips	3
24	Large Water Plug	2
25	Small Water Plug	2
26	Water Shield	2

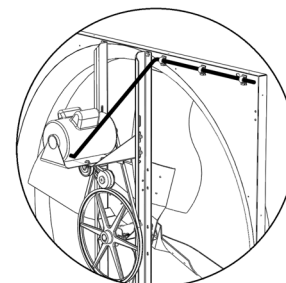

Power Cable Path

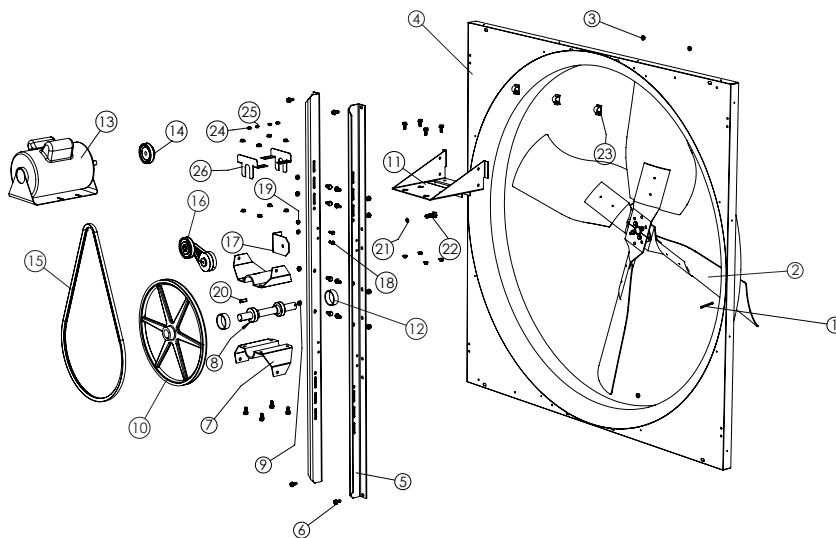

ADR COMPONENTS		
CODE	DESCRIPTION	QTY
1	Propeller	1
2	5/16 Whiz Lock Nut	4
3	Orifice	1
4	5/16 X 3/4 Bolt	4
5	Support Angle	2
6	5/16 X 3/4 (Bolt)	4
7	5/16 Whiz Lock Nut	4
8	Motor Base	1
9	Motor	1
10	Shaft	1

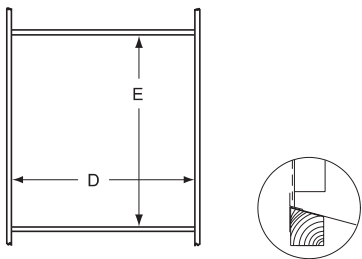
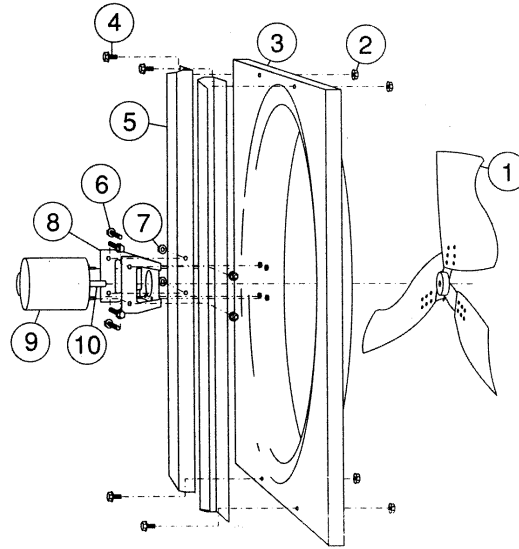

INSTALLATION IN WSS WALL HOUSING

Provide an opening in the wall of the building according to the dimensions in the chart. (See pages 3 & 4 for installation.)

For fan spacing, refer to "F" dimension.

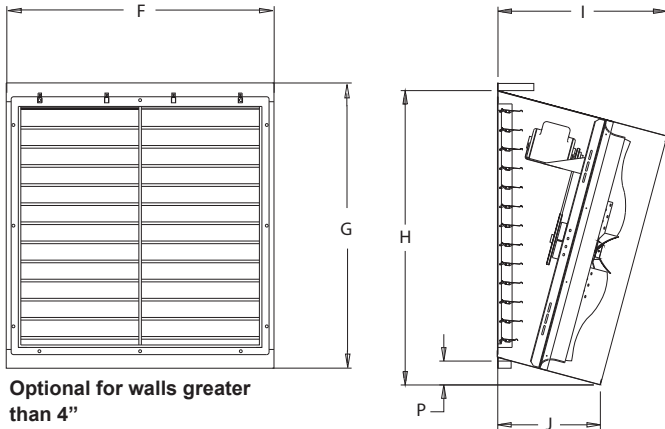

CAUTION! Guards are strongly recommended when the fan is installed within eight (8) feet of floor, working level or within reach of personnel. Guards complying with OSHA regulations are available as optional equipment. Review OSHA Codes and obtain a quotation.

FAN	Framed Opening Dimension for 4" Wall				F		G		H		I		J		P	
	D (Width)		E (Height)		IN	mm	IN	mm	IN	mm	IN	mm	IN	mm	IN	mm
	IN	mm	IN	mm												
BDR/ADR36	40.75	1035	42.75	1086	43.38	1102	45.15	1147	46.00	1168	27.14	689	17.22	437	3.25	83
BDR48	54.75	1391	57.25	1454	57.38	1457	58.86	1495	62.64	1591	33.06	840	19.50	495	5.39	137
BDR54	60.75	1543	63.50	1613	63.50	1613	66.13	1680	69.33	1761	35.31	897	19.98	507	5.83	148

INSTALLATION IN WSSC WALL COLLAR

INSTALLATION IN WSSC WALL COLLAR

Provide an opening in the wall of the building according to the dimensions in the chart. (See pages 3 & 4 for installation.)

For fan spacing, refer to "N" dimension on page 1.

For installation of the diffuser, refer to Form 610254 (provided with the diffuser).

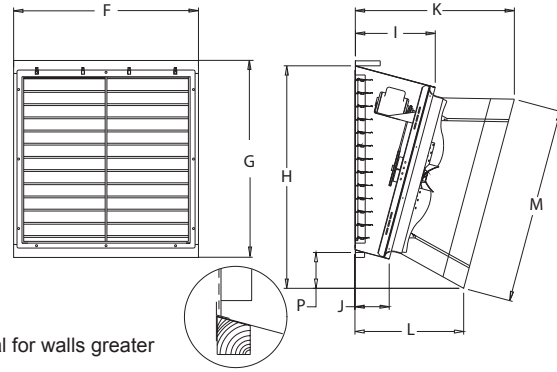

Optional for walls greater than 4"

CAUTION! Guards are strongly recommended when the fan is installed within eight (8) feet of floor, working level or within reach of personnel. Guards complying with OSHA regulations are available as optional equipment. Review OSHA Codes and obtain a quotation.

FAN	Framed Opening Dimension for 4" Wall				F		G		H		I		J		K		L		M		P	
	D (Width)		E (Height)		IN	mm	IN	mm	IN	mm	IN	mm	IN	mm	IN	mm	IN	mm	IN	mm	IN	mm
	IN	mm	IN	mm																		
BDR/ADR36	40.75	1035	42.75	1086	43.38	1102	45.15	1147	51.82	1316	20.73	527	10.71	272	33.75	857	22.25	565	45.13	1146	9.07	230
BDR48	54.75	1391	57.25	1454	57.38	1457	58.86	1495	67.50	1715	23.20	589	9.44	240	48.24	1225	32.98	838	59.45	1510	10.25	260
BDR48J2	54.75	1391	57.25	1454	57.38	1457	58.86	1495	70.43	1789	23.20	589	9.44	240	53.36	1355	38.27	972	62.38	1584	13.18	335
BDR54	60.75	1543	63.50	1613	63.50	1613	66.16	1680	76.84	1952	24.66	626	9.30	236	52.33	1329	34.82	884	67.00	1702	13.34	339

INSTALLATION

- CAUTION!** This unit has rotating parts and safety precautions should be exercised during installation, operation and maintenance.
 - WARNING!** Do not use fans in hazardous environments where the fan's electrical system could provide ignition to combustible or flammable materials, unless the unit is specifically built for that hazardous environment.
 - CAUTION!** Guards must be installed when fan is within reach of personnel or within eight (8) feet (2.5 m) of working level or when deemed advisable for safety.
- #### Installation With Slant Wall Housing
- To install a fan mounted in a slant wall housing when the wall thickness is 4" or less, provide a rectangular opening in the wall equal to D and E dimension shown in fan chart. It is preferable to frame the opening with 2 x 4 material, or a metal frame in metal buildings or greenhouses. When the wall thickness is more than 4", the height of the rectangular opening should be 1 inch less than the height shown in fan chart and the bottom of the opening should be slanted approximately 15° as shown in the inset.
 - Slide the fan wall housing through the inside of the framed opening in the wall. Fasten with bolts or screws provided by the installer. Position box so the top panel slants down from the horizontal. Caulk between the top flanges and the wall.
 - Mount the automatic damper to inside the fan wall housing. Do this by inserting the automatic damper up into the groove at the top of the fan housing, then let it drop into the bottom groove.
 - A distance of at least one and one-half times the diameter of the fan should be allowed between the fan inlet or discharge opening and any adjacent wall or large obstruction.
 - CAUTION!** Before proceeding, make sure electrical service to fan is locked in "OFF" position.
 - All wiring should be in accordance with local ordinances and the National Electric Code.
 - Before starting, check all fasteners for tightness particularly in the propeller hub. Turn the propeller by hand to make sure it rotates freely and that the blades do not strike the orifice.
 - WARNING!** Check voltage being supplied to the fan to see that it corresponds with the motor nameplate voltage; high or low voltage can seriously damage the motor. On multi-voltage motors, check motor terminal connections to make sure motor is internally connected for voltage being supplied. Motor wiring diagram is located on the side of the motor or in the motor wiring compartment. Extra care should be taken when wiring two speed motors since improper connections will damage motor and void motor warranty. Leave enough slack in wiring to allow for motor movement when adjusting belt tension. Route motor power wiring using the supplied wire clips on the back of the orifice as shown in the diagram "Power Cable Path" on page #1 of the installation instructions. After routing power wire through the clips on the orifice then turn the wiring 90 degrees using a large radius and route along the top of the

housing side panel using supplied wire clips. Then route power wire through the knockout in the top flange using a proper strain relief for the wire size chosen. Knockout is located in the upper right corner as viewed from the intake side of the fan. Please insure that after proper routing of power wiring, there is no interference with the shutters normal operation.

9. Apply power momentarily and compare the rotation of the impeller with the directional arrow on fan. In the case of three

phase motors, the direction can be changed by interchanging any two of the three motor leads. In the case of the single phase motors, the reversing instructions will appear on the wiring diagram in the motor wiring compartment.

10. When supply type fans are used with motorized wall dampers, it is necessary that a time delay switch be used between the power source and the fan motor which will allow the damper to fully open before the fan is activated.

BELT TIGHTENER MAINTENANCE BELT DRIVE MODELS ONLY

CAUTION: Before proceeding, make sure electrical service to fan is locked in "OFF" position.

1. If the belt stretches enough that the belt tightener does not keep the belt tight, the belt tightener can be adjusted. Start by loosening the 3/8 inch bolt holding the belt tightener to the belt tightener base.
2. Place a wrench on the hex nut in the belt tightener body as shown in Figure 1 and a wrench on the belt tightener mounting fastener.
3. Using the wrench on the belt tightener body, apply pressure in the appropriate direction (see Figure 1) until the belt is properly tensioned. Note: The belt tightener body has marks on it as shown in Figure 2 representing degrees. The proper alignment after tightening the mounting bolt is shown in Figure 3.
4. With the belt tightener securely held in position, tighten the belt tightener mounting bolt.
5. If the belt tightener cannot be adjusted without hitting another part of the fan, tighten the belt by adjusting the fans motor base toward the top of the fan with the belt tightener mounting bolt loose (see item 1). Continue the adjustment at Item 2.

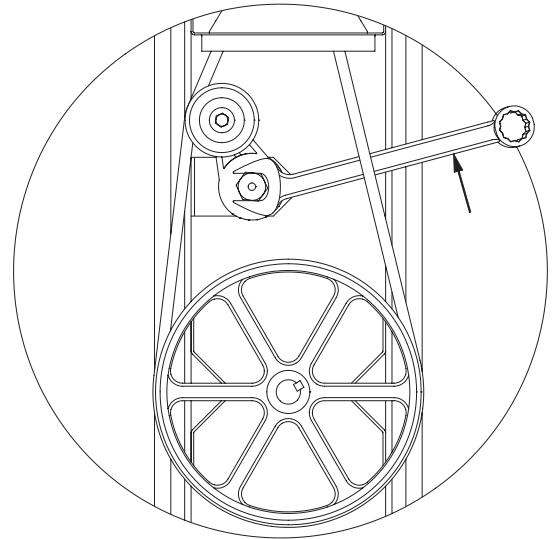

FIGURE 1

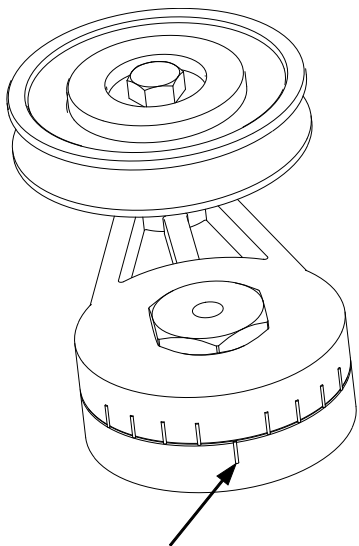

FIGURE 2

BASE MARKER

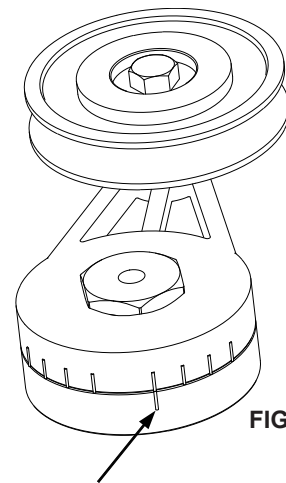

FIGURE 3

BASE MARKER
AND TIGHTENER
ALIGNMENT

MAINTENANCE

1. Motors supplied by Acme have pre-lubricated bearings. Consult information printed on motor for lubrication instructions.
2. Propeller shaft bearings are pre-lubricated, sealed and require no service.
3. Check belt tension after first 48 hours of operation and annually thereafter. Belt should depress its width when pressed firmly inward at midway point between the pulleys. Too much tension will damage bearings; belt should be tight enough to prevent slippage. When replacing worn belt, replace motor pulley if "shoulder" is worn in groove.

WARNING! Do not operate at higher speeds than rated. Do not replace motor pulley with a larger diameter pulley. Do not replace the fan pulley with one smaller in diameter. The pulley ratios are set so that the motor will not be overloaded.

4. If motor requires replacement, one comparable to the original with the same service factor and enclosure must be used.
5. If propeller shaft bearings need replacement, replace with bearings comparable to original equipment. The new bearing must be installed with the neoprene ring. The BDR family uses a 25mm shaft with pressed on bearing. Shaft and bearing kits are available through any ACME dealer. **WARNING: Do Not use 1 inch bearings on BDR shafts.** If pressing new bearings onto the shaft, be careful to place the new bearings in the correct shaft position. Any misalignment will cause bearing failure.
6. The customer/building engineer/architect is responsible for ensuring the structural integrity of the supporting wall. The wall supporting fans should be rigid enough to not only support the mass of the fan assemblies, but also stiff enough to impede any natural harmonic frequencies and pressures created by rotating mechanical devices, such as fans.
7. **Cleaning on or near Bearing Housing, Bearings, and Fan Shaft** – It is recommended that the bearing housing, bearings, and fan shaft **NEVER** be pressure washed or premature bearing failure may be induced. The soiled bearing housing should be brushed clean with a stiff bristle brush, then a light coat of Simple Green spray cleaner applied, allowing to soak for 30 seconds, and wiping away cleaning residue with a clean dry cloth. At this time, check to make sure all bolts in the bearing housing are secure. **After cleaning and washdown, let the fans run for 4 hours to properly dry.**

SET SCREW TIGHTENING SCHEDULE

1. Before initial operation of the fan, tighten set screws according to the procedure outlined below.
2. After 500 operating hours or three months, whichever comes first, tighten set screws to the full recommended torque.
3. At least once a year, tighten set screws to the full recommended torque.

PROCEDURE FOR TIGHTENING SET SCREWS IN BEARINGS AND HUBS

One Set Screw Application

Using a torque wrench, tighten the set screw to the torque recommended in Table 1.

Two Set Screw Application

1. Using a torque wrench, tighten one set screw to half of the torque recommended in Table 1.
2. Tighten the second set screw to the full recommended torque.
3. Tighten the first set screw to the full recommended torque.

Table 1. Recommended Tightening Torque for Set Screws

Set Screw Diameter	Torque (in-lbs)
#10	35
1/4	80
5/16	126
3/8	240
7/16	384
1/2	744
9/16	1080
5/8	1500
3/4	2580
7/8	3600
1	5400

VARIABLE FREQUENCY DRIVES AND MOTORS

There are occasions when a Variable Frequency Drive (VFD) will cause poor motor performance and possible damage. To avoid these problems, the Company recommends the following:

1. Select compatible motor and VFD inverter; if possible, the motor and the inverter should be from the same manufacturer or at least the inverter selected should be recommended by the motor manufacturer.
2. A motor certified for VFD operation must be used. Operation of a motor with TOL should not be used with VFD's.

NOTE: The Company will not honor motor warranty claims if the customer fails to follow these recommendations.

TERMS AND CONDITIONS OF SALE

ACCEPTANCE All orders and sales are subject to written approval and acceptance by an executive officer of Acme Engineering & Manufacturing Corporation at Muskogee, Oklahoma, (the "Company") and are not binding on the Company until so approved.

DELIVERY All shipping and delivery dates are estimated only. No delays in delivery will subject the Company to any costs, damages or fees for late delivery. Delivery of the products herein specified shall be made F.O.B. point of shipment, unless otherwise stated. The Company shall not be liable for delay due to causes beyond its reasonable control, such as Acts of God, acts of the purchaser, acts of civil or military authorities, priorities, fires, strikes, floods, epidemics, war, riots, delays in transportation, car shortages, and inability, due to reasons beyond its reasonable control, to obtain necessary labor, material, or manufacturing facilities. In the event of such a delay, the date of delivery shall be extended for a period equal to the time lost by reason of the delay.

TERMS OF PAYMENT If, in the judgment of the Company, the financial condition of the purchaser at any time does not justify continuation of manufacture or shipment on the terms of payment specified, the Company may require full or partial payment in advance.

Pro rata payments shall become due as shipments are made. Each shipment or delivery shall constitute a separate sale, and the default of any shipment or delivery shall constitute a separate sale, and the default of any shipment or delivery shall not vitiate the contract as to other shipments or deliveries.

SALES AND SIMILAR TAXES The Company's prices do not include sales, use, excise, or similar taxes. Consequently, in addition to the price specified herein, the amount of any present or future sales, use, excise, or other similar tax applicable to the sale of the product herein shall be paid by the Purchaser, or in lieu thereof

the Purchaser shall provide the Company with a tax exemption certificate acceptable to the taxing authorities.

CANCELLATION Any contract resulting from the Purchaser's order may be canceled by the Purchaser only by negotiations and upon payments of reasonable cancellation charges which will take into account expenses already incurred and commitments made by the Company.

DESIGN CHANGES The Company reserves the right to make changes in design, improvements and additions in and to its products any time without imposing any liability or obligations to itself to apply or install the same in any product manufactured by it.

TITLE The title and right of possession of the products sold herein shall remain with the Company and such products shall remain personal property until all payments herein (including deferred payments whether evidenced by notes or otherwise) shall have been made in full in cash and the Purchaser agrees to do all acts necessary to perfect and maintain such right and title in the Company.

PRICE ADJUSTMENTS Prices are subject to change upon notice by the Company. Prices on existing orders are subject to surcharges in the event of cost increases of metals and transportation. All complete component accessory material manufactured by others and furnished with the Company's products such as motors, drives, vibration equipment, controls or other completely assembled component structures, are subject to adjustment to the price at time of shipment regardless of the date of original order entry.

SAFETY ACCESSORIES The Company manufactures products designed to serve multiple applications and offers a wide range of safety equipment, including guards and other devices, as may be required to meet

customer specifications. Without exception, the Company recommends that all orders include applicable safety devices. Products ordered without applicable safety devices is clearly the responsibility of the Purchaser. Further, the Purchaser warrants that it has determined and acquired any and all safety devices required for products sold by the Company. Weather covers and guards for motor and V-belt drives, couplings, shafts and bearings, along with inlet and outlet screens, are optional accessories noted in the price list.

GOVERNING LAW The rights, obligations and remedies of Purchaser and the Company, the interpretation of these terms and conditions and the sale of products by the Company shall be governed by Oklahoma law, without regard to any principles of conflict of laws.

ARBITRATION Any dispute arising under or in connection with these terms and conditions or the sale of products shall be settled by binding arbitration administered by the American Arbitration Association under its Commercial Arbitration Rules, and judgment on the award rendered by the arbitrator may be entered in any court having jurisdiction thereof. The dispute shall be resolved by one neutral arbitrator who shall have no affiliation with either Purchaser or the Company and shall be selected by the American Arbitration Association office in Dallas, Texas. The arbitration proceedings shall be held in Muskogee, Oklahoma.

APPLICABLE DOCUMENTS The agreement between the Company and the Purchaser relating to the products includes these terms and conditions of sale, any applicable installation and maintenance instructions provided by the Company and any terms appearing on the Company's quotation, sales order acknowledgment and invoice.

WARNING Acme products are designed and manufactured to provide reliable performance but they are not guaranteed to be 100% free of defects. Even reliable products will experience occasional failures and this possibility should be recognized by the Purchaser and all End Users. If these products are used in a life support ventilation system where failure could result in loss or injury, the Purchaser and all End Users should provide adequate back-up ventilation, supplementary natural ventilation or failure alarm system, or acknowledge willingness to accept the risk of such loss or injury.

WARNING DO NOT use in HAZARDOUS ENVIRONMENTS where fan's electrical system could provide ignition to combustible or flammable materials unless unit is specifically built for hazardous environments. Comply with all local and national safety codes including the National Electrical Code (NEC) and National Fire Protection Act (NFPA).

CAUTION Guards must be installed when fan is within reach of personnel or within eight (8) feet (2.5 m) of working level or when deemed advisable for safety.

DISCLAIMER The Company has made a diligent effort to illustrate and describe the products accurately in all Company literature; however such illustrations and descriptions are for the sole purpose of identification and do not express or imply any warranty.

LIMITED WARRANTY

WARRANTY AND DISCLAIMER: The Company extends this limited warranty to the original purchaser and warrants that products supplied by the Company, shall be free from original defects in workmanship and materials for two years from date of shipment (except for the warranty periods noted for products listed below), provided same have been properly handled, stored, installed, serviced, maintained and operated. This warranty shall not apply to products which have been altered or repaired without the Company's express authorization, or altered or repaired in any way so as, in the Company's judgment, to affect its performance or reliability, nor which have been improperly installed or subjected to misuse, negligence, or accident, or incorrectly used in combination with other substances. The Purchaser assumes all risks and liability for results of use of all products.

Evaporative cooling pads are warranted to be free of defects in materials and workmanship for a period of two years from date of shipment provided same have been properly handled, stored, installed, serviced, maintained and operated; and further, not subjected to excessive heat, corrosive agents or chemicals, or mechanical abuse that may cause tearing, crushing or undue deterioration, nor used on a system or in a manner other than that for which it was designed as explained in the product literature.

The following products are warranted to be free of defects in materials and workmanship for the periods shown from date of shipment: Acme's exclusive duplex split pillow block bearings and shaft five years, belts one year, Polyethylene tubing 90 days, AIR40 Heater warranty one year, AIR40 Emitter warranty three years and DDP fan lifetime warranty on its propeller, cone, and housing.

LIMITATION OF REMEDY AND DAMAGES: All claims under this warranty must be made in writing and delivered to P. O. Box 978, Muskogee, Oklahoma, 74402, within 15 days after discovery of the defect and prior to the expiration of two years from the date of shipment by the Company of the product claimed defective, and Purchaser shall be barred from any

remedy if Purchaser fails to make such claim within such period.

Within 30 days after receipt of a timely claim, the Company shall have the option either to inspect the product while in Purchaser's possession or to request Purchaser to return the product to the Company at Purchaser's expense for inspection by the Company. The Company shall replace, or at its option repair, free of charge, any product it determines to be defective, and it shall ship the repaired or replacement product to Purchaser F.O.B. point of shipment; provided, however, if circumstances are such as in the Company's judgment to prohibit repair or replacement to remedy the warranted defects, the Purchaser's sole and exclusive remedy shall be a refund to the Purchaser of any part of the invoice price, paid to the Company, for the defective product or part.

The Company is not responsible for the cost of removal of the defective product or part, damages due to removal, or any expenses incurred in shipping the product or part to or from the Company's plant, or the installation of the repaired or replaced product or part.

The warranties set forth above do not apply to any components, accessories, parts or attachments manufactured by other manufacturers; such being subject to the manufacturer's warranty, if any. To the extent not prohibited by the manufacturer's warranty, the Company shall pass through to Purchaser such manufacturer's warranty.

THE COMPANY'S WARRANTY IS IN LIEU OF ALL OTHER WARRANTIES, EXPRESS OR IMPLIED, ARISING BY LAW OR OTHERWISE, INCLUDING WITHOUT LIMITATION THE IMPLIED WARRANTIES OF MERCHANTABILITY AND FITNESS FOR A PARTICULAR PURPOSE, WHICH ARE HEREBY EXPRESSLY DISCLAIMED AND WAIVED. THIS WARRANTY CONSTITUTES THE COMPANY'S SOLE AND EXCLUSIVE WARRANTY FOR DEFECTIVE GOODS AND PURCHASER'S SOLE AND EXCLUSIVE REMEDY FOR DEFECTIVE PRODUCTS.

No employee, agent, dealer, or other person is authorized to give any warranties on behalf of the Company or to assume for the Company any other liability in connection with any of its products except in writing and signed by an officer of the Company.

REPLACEMENT PARTS If replacement parts are ordered, purchaser warrants that the original components in which these replacement parts will be placed are in satisfactory working condition, and

when said replacement parts are installed, the resultant installation will operate in a safe manner, at speeds and temperatures for which the original product was purchased.

TECHNICAL ADVICE AND RECOMMENDATIONS, DISCLAIMER: Notwithstanding any past practice or dealings or any custom of the trade, sales shall not include the furnishing of technical advice or assistance or system design. Any such assistance shall be at the Company's sole option and may be subject to additional charge.

The Company assumes no obligation or liability on account of any recommendations, opinions or advice as to the choice, installation or use of products. Any such recommendations, opinions or advice are given and shall be accepted at Purchaser's and End User's risk and shall not constitute any warranty or guarantee of such products or their performance.

LIMITATION OF LIABILITY The cumulative liability of the Company to the Purchaser and any other persons for all claims in any way relating to or arising out of the products, including, but not limited to, any cause of action sounding in contract, tort, or strict liability, shall not exceed the total amount of the purchase price paid for those products which are the subject of any such claim. This limitation of liability is intended to apply without regard to whether other provisions of this agreement have been breached or have proven ineffective even if the Company has been advised of the possibility of such claims or demands. In no event shall the Company be liable to the Purchaser or any other person for any loss of profits or any incidental, special, exemplary, or consequential damages for any claims or demands brought by the Purchaser or such other persons.

INDEMNITY The Company's maximum liability to Purchaser and to any end user is as set forth above. The Company makes no warranty to anyone for any products not manufactured by the Company and shall have no liability for any use or installation of any products (whether manufactured by the Company or other manufacturers) not specifically authorized by this sale. Purchaser acknowledges various warnings by the Company regarding the products and its installation and use. If the Company incurs any claims, lawsuits, settlements, or expenses (including attorney fees) for any loss, injury, death or property damage including, but not limited to, claims arising out of the Purchaser's or any end user's installation or use of the products, the Purchaser shall indemnify and hold the Company harmless.



ACME ENGINEERING AND MANUFACTURING CORPORATION
P.O. Box 978
Muskogee, Oklahoma 74402
Telephone 918/682-7791
Fax 800/382-2263
www.acmefan.com